

PRODUCT DATA SHEET

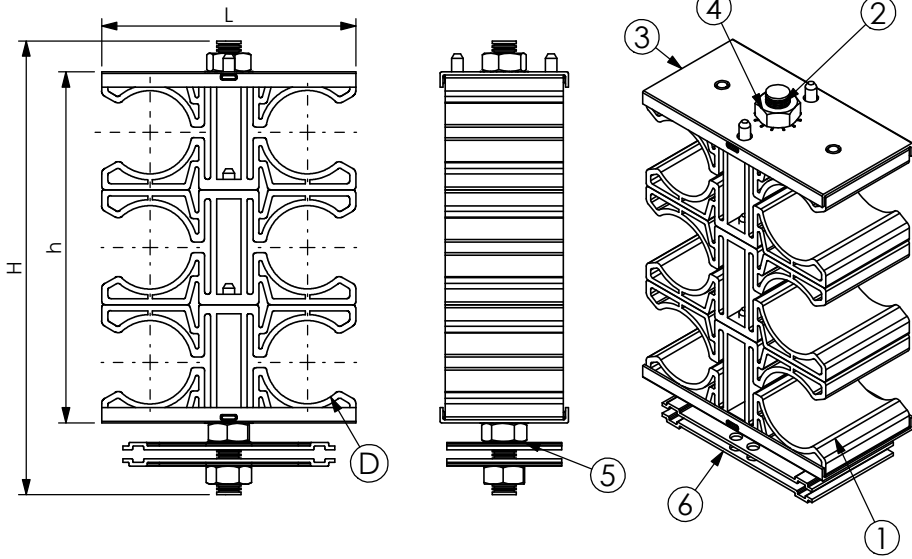

A) SPECIFICATIONS

- 1 Calibrated twin black saddles made in H.D.P.E
- 2 Stainless steel threaded bar BFI M8
- 3 Stainless steel pressure plate PSAL
- 4 Stainless steel hexagonal nut DAI 8
- 5 Stainless steel flat Washer REI 8
- 6 Stainless steel pressure plate PUC 70

B) RESISTANCE TESTS

UV Test BS-ISO 105-B06
 Vibration test conforming to UNI 60068-2-6
 Operating temperature: -30°C +120°C

C) PACKAGING INFORMATION

Packing in boxes.
 Label indicating:
 product code, article, quantity,
 production batch,
 FIMO logo and figure.
 (Customer code on request).

D) MOUNTING INSTRUCTIONS

On request

CODE	ARTICLE	ø D	L	h	H	BOX	WEIGHT
61 1565 6012	LCL/ 6x1/2"	15 - 17	62	125	84	20	270
61 1565 6078	LCL/ 6x7/8"	27 - 29	84	150	117	20	305
61 1565 6114	LCL/ 6x1.1/4"	38 - 40	102	200	153	20	410
61 1565 6158	LCL/ 6x1.5/8"	50 - 52	119	250	186	20	510

RI	DATE	DR	DATE	AP	Description:
02					LCL - LCO+2 PUC 70 steel pressure plate <ul style="list-style-type: none"> • Side Insertion of Cables • Elastic Prefixing • Manual Final Locking
01					
00	03/11/2015	G.S.	03/11/2015	A.V.	
1 ST EMISSION					
					Use: Fastening of 6 cables on steel wire cable trays